

Galileo IOV System Initialization and LCVTT Technique Exploitation

M. Gotta⁺, F. Gottifredi⁺, S. Piazza⁺, D. Cretoni^{*}, P.F. Lombardo^{*}, E. Detoma[°]

⁺ Alcatel Alenia Space Italia S.p.A.,

e-mail: monica.gotta@aleniaspazio.it, Phone: +39-06-4151.3134

^{*} Univ. La Sapienza (Rome),

e-mail: lombardo@infocom.uniroma1.it, Phone: +39-06-44585.472

[°] Sepa S.p.A., e-mail: edoardo.detoma@separatorino.it, Phone: +39-011-0519220

Abstract. Satellite-based navigation systems uses one-way ranging measurements for system orbit estimation and time-keeping, due to its operational advantage when compared with two-way ranging technique, in terms of complexity of ground monitoring stations (completely passive and requiring a simple omnidirectional antenna to track all the satellites in view). However, a sufficient number of simultaneous independent measurements is required to solve the system unknowns: in particular simultaneous visibility of multiple stations by an individual satellite (allowing to separate the ground stations clocks contributions since the SVs clocks disappear), as well as simultaneity of observations from the same monitor stations of a large number of satellites (allowing to recover the SVs clocks parameters, since the GSS clocks drop out) is the key to an effective separation in the solution of the clock contributions from the pseudo-ranges.

In the Galileo IOV phase (consisting of 4 satellites on two orbital planes and a ground network of 20 Sensor Stations), the first condition is clearly fulfilled, however the second condition is not met for a considerable part of the time. If two GSSs do not see simultaneously a single Galileo satellite, they will not be able to estimate their clocks time and frequency drifts, i.e. they will not be synchronized. The free running clocks will essentially enter a holdover mode, were the relative time between the two stations will be slowly drifting as a function of the initial conditions and the stability of the clocks. The ground stations synchronization will gradually degrade with time and when a satellite will rise on the horizon they will be essentially not synchronized to the extent required to carry on a one-way-based Orbit Determination & Time Synchronization (OD&TS).

During the IOV phase, the limited number of satellites available and the peculiar characteristics of the Galileo orbits will make difficult for the Orbit Determination and Time Synchronization to start producing meaningful data, therefore some form of intermediate operational configuration must be sought to help in the OD&TS process initialization.

The paper will address the proposed solution to overcome the problem of Galileo system initialization starting from the intermediate configuration with first 2 satellites (first IOV Launch) up to final IOV Configuration after second IOV launch. The proposed solution will be based on a limited use of GPS to insure the synchronization of the Galileo Sensor Stations, relying on the exploitation of the Linked Common View Time Transfer (LCVTT) Technique, while the Galileo Orbit Determination and SVs clocks characterization will be carried on autonomously and independently by GPS, in a two step process, up to the achievement of the IOV Configuration with 4 satellites, when the nominal Orbit Determination and Time Synchronization process will be operated.

Moreover the paper will address the development of the LCVTT Algorithm, carried on as part of development of the infrastructure aiming to support the Galileo Verification Phase currently under definition as part of Galileo Phase C/D/E1 contract. The algorithm design and implementation will be presented together with the validation carried out (both for LCVTT and MLCVTT) to verify that the synchronization accuracy is adequate to support the Galileo System Initialization.

1 Introduction

Galileo, as the European-controlled world-wide satellite navigation system, is conceived to be the contribution to the next GNSS (Global Navigation Satellite System) system, namely the global infrastructure for the integrated management of the multimodal mobility on world scale (see [1]). Galileo will be an autonomous system but contemporarily compatible and, possibly, interoperable at the maximum extent with other navigation systems, particularly with the GPS system. Galileo will be under the control of a civil authority and will provide basic services at global coverage level for a wide range of applications in different transport domains, like road, railway, air, maritime and personal mobility, and suitable to fulfil various user needs spread over a wide professional areas.

The Galileo Programme is jointly supported by the European Commission and by the European Space Agency and is currently facing its C/D/E1 Phase, focused to the development, deployment and validation of an initial part of the System, known as IOV Configuration, composed of a reduced Space Segment and a reduced Ground Segment compared with the Final Operation Capability (FOC).

The Galileo IOV constellation shall be a sub-set of the Galileo FOC constellation of 30 satellites, comprising four satellites, in two different planes. The Ground Segment will be also a sub-set of the final one and is reported in Table 1.

The IOV reduced architecture has a high impact on Navigation Performance in IOV, leading of course to a degradation on accuracy and availability of navigation solution.

Several are the problems encountered when trying to work with an IOV constellation:

- The lack of measurements associated to each GSS station make difficult to compute a snapshot bias per epoch as currently envisaged for FOC.
- Furthermore, for long intervals of time, the satellites are not in view of the master clock station, and hence all the measurements at those epochs are rejected (more than half the total number of observations), hence degrading the orbit and clock estimations.
- Finally, the Orbit Determination and Time Synchronisation algorithm often fails because the normal matrix cannot be inverted, due to the bad conditioning of the system from the mathematical perspective. This can be sometimes overcome by restricting the a-priori covariance of the clock estimation (that implies constraining the normal matrix).

Moreover, in order to reach its on-line IOV Operation, the System needs to be initialized, as to reach convergence (especially in its Ground Processing, namely Orbit

Table 1. Galileo IOV configuration.

	IOV system configuration
Satellites	4
S-band TTC stations	2
C-band up link stations	5
L-band sensor stations	20
Galileo Control Centre	1

Determination & Time Synchronization) and allow starting the nominal IOV Test Campaign. In the following section the problem of system initialization, especially in the reduced IOV Configuration, will be treated and solution will be presented to support this activity.

2 IOV System Inizialization

Satellite-based navigation systems use one-way ranging measurements for system orbit estimation and time-keeping. The operational advantage of one-way ranging versus two-way ranging is obvious when one considers the complexity of the ground monitoring stations in the two approaches. One way requires a simple omnidirectional antenna to track all the satellites in view, is completely passive (non-transmitting) and the station can be deployed or redeployed with minimum effort, requiring only a surveyed location, making it ideal for a military system. On the contrary, a two way ranging station requires a complex transmitting equipment, a large directional antenna and, as a consequence, will not be able to simultaneously track multiple satellites and it is expensive to deploy.

One-way ranging measurements are termed “pseudo-ranges” since they contain the system clocks contributions, namely the space vehicle (SV) clock and the monitor station (GSS in Galileo) clock in addition to the propagation delay caused by finite propagation velocity v_p over the range:

$$\tilde{\rho} = v_p \cdot (\Delta t_{prop(SV - GSS)} + \Delta t_{GSS - SV}) = v_p \cdot [\Delta t_{prop(SV - GSS)} + (\Delta t_{SV} + \Delta t_{GSS})] \quad (1)$$

where in the last term I have expressed the contribution to the pseudo-range measurement as the sum of the offsets of the individual clocks with respect to the system time which, for a composite clock solution, must satisfy, in principle, the relationship:

$$\sum_i w_i \cdot \Delta t_{SV,i} + \sum_j w_j \cdot \Delta t_{GSS,j} = 0 \quad (2)$$

and the sums are carried on over all SVs and GSSs clocks in the system, each properly weighted with weights w_i and w_j .

The fundamental assumption of the one-way ranging technique is the capability to separate the three contributions to the pseudorange measurements, given a sufficient number of measurements. This will yield range observables, used to update the estimate of the orbit, and time offsets observables, to estimate the clock offsets and

derive from the latter the clock parameters (phase and frequency offsets and drift) subject to the condition (2).

However, a sufficient number of independent measurements is required to solve the system unknowns, but additional constraints apply for the term separation to be effective, namely that a sufficient number of simultaneous independent measurements is available. Simultaneity of observations from the same monitor stations of a large number of satellites, as well as simultaneous visibility of multiple stations by an individual satellite, is the key to an effective separation in the solution of the clock contributions from the pseudo-ranges.

Single and double-differencing techniques, widely used for data reduction in the geodetic community, will be of help in understanding the underlying physical rationale. When two satellites are simultaneously observed by a single monitor station (Fig. 1), the first difference of the two pseudorange drops the common MS clock term from the observable.

Notice that we assume that the ionospheric propagation effects are completely removed by the use of the two-frequency technique and tropospheric effects are common to the two measurements, so they cancel out too. This yields a nice observable for the SV clocks. When a single satellite is simultaneous in view of two ground stations, the situation depicted in Fig. 2 applies.

Again, the first difference drops the SV clock and yields an observable which contains only the MS clocks contribution. However, while the same considerations for the ionospheric propagation still applies as before, now the tropospheric delay is not “common mode” and may (will) affect the final estimation of the range and GSS clock estimation.

Monitor stations clocks estimation (prediction) is affected by “local” (mainly due to the wet component of the troposphere) propagation delays and by the stability in

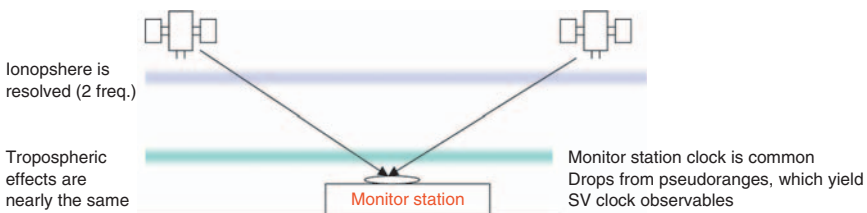

Fig. 1. Simultaneous observations from a single monitor station.

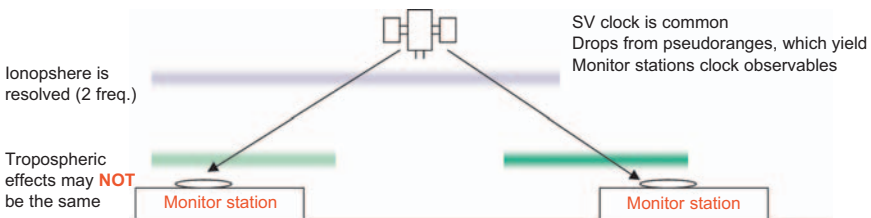

Fig. 2. Single satellite in simultaneous view of two monitor stations.

the equipment delays which are not correlated. Hence, errors propagate to orbit determination and indirectly affect the final user positioning/timing accuracy.

Since a second difference of a number of simultaneous observations having in common the SVs and the MSs will yield the orbit estimation free of clock terms, it is intuitive that the tropospheric effects are the major source of error left in the GSS clocks state estimate and, as a consequence, of the GSS clock states error projection on the orbit estimate.

Therefore, use and improvement of meteo data and tropospheric propagation models is of importance in the overall system error budget. In parallel, an independent monitoring capability of the MS clock behaviour (by two-way time transfer, for instance) may help in highlighting possible mismodeling effects in the troposphere as well as improving the capability to verify the MS clocks state estimate and their final contribution toward the orbit estimation errors.

From the previous considerations, it is clear that for the Orbit Determination and Time Synchronization Process to produce an optimum solution for the SVs orbits and system clocks two conditions must be fulfilled: that each satellite be continuously and simultaneously in view of more ground stations; this allows to separate the ground stations clocks contributions since the SVs clocks disappear; that each station be continuously and simultaneously in view of more than one satellite; this allows to recover the SVs clocks parameters, since the GSS clocks drop out.

In the Galileo IOV phase, the first condition is clearly fulfilled, however the second condition is not met for a considerable part of the time (as explained in Section 1). If two GSSs do not see simultaneously a single Galileo satellite, they will not be able to estimate their clocks time and frequency drifts, i.e.: they will not be synchronized. The free running clocks will essentially enter a holdover mode, were the relative time between the two stations will be slowly drifting as a function of the initial conditions and the stability of the clocks. The ground stations synchronization will gradually degrade with time and when a satellite will rise on the horizon they will be essentially not synchronized to the extent required to carry on a one-way-based OD&TS.

During the IOV phase, the limited number of satellites available and the peculiar characteristics of the Galileo orbits will make difficult for the OD&TS to start producing meaningful data, therefore some form of intermediate operational configuration must be sought to help in the OD&TS process initialization. The proposed solution to overcome this problem is based on a limited use of GPS to insure the synchronization of the GSSs, while the orbit determination and SVs clocks characterization will be carried on autonomously and independently by GPS.

The IOV phase will be characterized by three distinct temporal situations:

- prior to the availability of the first two satellites in orbit, the Ground Mission Segment will be the only component of the system supporting the navigation function that will be fully operative (phase I);
- the second phase (phase II) starts with the availability of at least two Galileo satellites in orbit, on the same orbital plane;
- phase III allows four Galileo satellites in orbit, on two orbital planes.

Due to the nature of the Galileo orbits, in full deployment the constellation repeats the same geometrical visibility with respect to a ground user every 8 hours, but with

different satellites¹. The same satellites will be visible with the same geometry by a fixed point on the Earth surface only every 10 days. Therefore, when a limited number of satellites are available, as in the IOV phase, it is understandable that the visibility conditions will occur at relatively sparse intervals.

The decision to implement a Master Clock configuration for the Galileo System Time (GST) turns into a distinct advantage under these rather restrictive conditions, since:

- GST becomes independent from the number of deployed system clocks, and is only based on the clocks ensemble at the PTF; therefore no discontinuity arises as new SVs or GSSs are added due to the new clocks or a redistribution of weights;
- the previous consideration implies that GST can be maintained at nominal performances well ahead of the deployment of the Space Segment and even before the full GMS is deployed, as long as the PTF is operative.

Therefore, during phase I we may safely assume that GST is running and available at nominal performances and that the deployed GSSs can be referred to GST via a GPS-based Linked Common View Technique, independently by the OD&TS but with a synchronization technique, the Common View, which is based on pseudorange measurements and therefore with resulting biases correlated to the OD&TS solution.

This allows to solve the problem discussed previously, that the GSSs need some form of external T&F synchronization due to the lack of continuous and simultaneous visibility of orbiting Galileo satellites.

Having a sufficient² knowledge of the GSSs relative time offset, independent of the availability of Galileo satellites, the OD&TS process can be started by exploiting the condition (i) above, i.e., that at least two stations are simultaneously in view of each SV³ in orbit.

By basing, at this stage, the OD&TS process on single differences of the observables, the SVs clocks cancel and all the observations contribute only to the orbit determination, i.e.: the Keplerian parameters plus the modelled (solar pressure) and unmodelled accelerations⁴.

Since:

- all the observables will contribute to the orbit determination only and
- a sufficient number of GSSs exist at this stage to provide an overdetermined solution and continuity of observations along the full orbit of the SVs, and moreover the observations can be time-correlated with a small degradation due to the

¹ For the GPS, the constellation repeats every (sidereal) day with the same satellites.

² It is assumed that the LCVTT will yield a relative synchronization between the GSSs (including the one located at the PTF) with an accuracy in the order of 5 ns, which yields an upper bound on one-way ranging of ≈ 1.5 m.

³ In this phase only two satellites will be available.

⁴ We assume that the prior knowledge of the gravitational field and perturbations from other bodies of the solar system or from the Earth (liquid and solid tides) is available, as it is, with the required accuracy to support an orbit determination with no degradation with respect to the system requirements.

parallel LCVTT process (due to the age of data in Crosslink Navigation Update Mode, see [2]), and

- because of the intrinsic high stability of the orbit with respect to the clocks

there is a high degree of confidence that the orbit determination process will converge quickly to an accurate solution.

Once the orbit is determined, the on-board clocks can be characterized “a posteriori” using the same orbital arc on which the orbit has been computed and the original observations. This is equivalent to an absolute one-way time transfer, where the ground clocks are known and the ranges are derived from the computed orbit. Subtracting these two quantities by the pseudoranges (observables) provided by all the stations in visibility of each satellite, yields the SVs clocks offsets in the form of a time series, from which the time and frequency offset (and frequency drift) can be estimated.

This two-steps process differs substantially by the final OD&TS operation by the fact that the solution is not provided in real-time but only in post-processing, no prediction is possible until the post-processing has produced a workable and stable solution, which in turn has to wait for the orbit determination to achieve a degree of stability and accuracy sufficient to support the SVs clocks characterization. The other major difference, at the algorithmic level, is in that two observables are used instead than one as in the operational OD&TS: the first difference of pseudoranges for orbit determination and the pseudorange for the SVs clocks characterization, both corrected “a priori” for the GSSs clocks offsets.

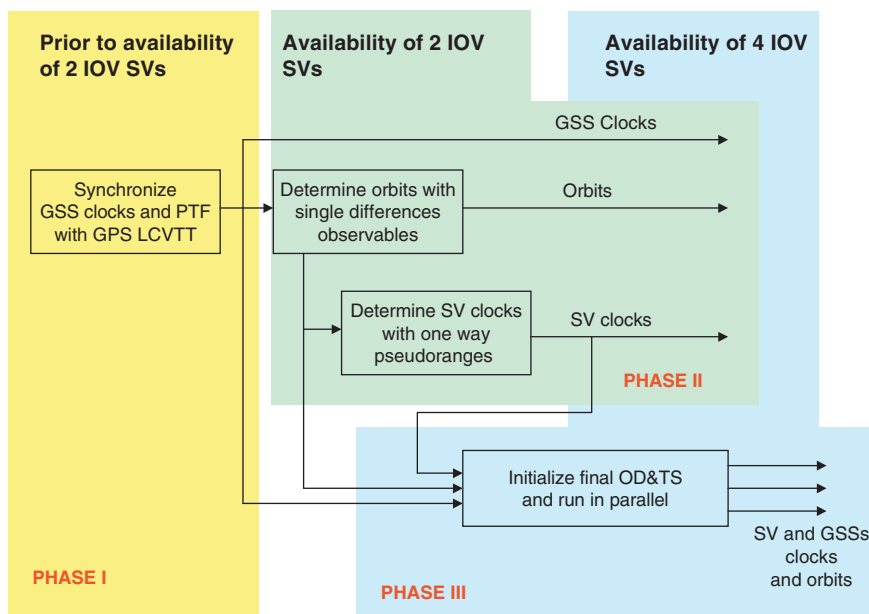

Fig. 3. Evolution of the OD&TS process prior & during IOV.

Accepting these limitations, the process should provide a good solution for the system parameters since what we have termed above as the phase II, i.e.: with only two satellites in orbit.

Once the orbit and clocks parameters are known with a sufficient degree of stability and accuracy, the final OD&TS process (Fig. 3) can be started in parallel, with initial conditions as provided by the previous process.

The rationale of the initialization is based on the “a priori” synchronization of the GSSs clocks by independent and external means. The use of Cs clocks under these conditions would provide benefits in insuring a better synchronization (small prediction error, see [3]) in the holdover mode, i.e. when the GSSs do not “see” any Galileo satellite that can be used for synchronization and they must rely on the clock stability and external measurements to keep a relative synchronization and a synchronization with GST.

In the next paragraph the development of a synchronization algorithm able to support System Inizialization by processing of GPS measurements collected at Galileo Sensor Stations is presented. Both the theoretical background and the implementation aspects will be treated, both with reference to Linked Common View and Multiple Path Linked Common View techniques (see [4], [5]).

3 LCVTT and MP-LCVTT

Using the Common-View Technique, provided there are enough satellites in common-view visibility between pair of stations, a number of sensor stations can be linked by implementation of LCVTT technique, to provide:

- the time offset between individual pairs of station clocks;
- the time offset between remote sites not in common view.

The situation is shown in Fig. 4 below, where only a few links are shown not to unnecessarily clutter the picture. The LCVTT allows not only to recover the time offset between adjacent stations, but by taking multiple differences also to measure the time offset between non adjacent stations, for instance, between Papeete and Kransoyarsk for the links shown.

This technique, although simple and computationally efficient, suffered several disadvantages. One of the most important is that using linked common view a single noisy site can decrease the precision of synchronization. An improvement of this technique can be obtained by synchronizing two remote station using a multiple common view path approach. In fact many possible links exist between two far stations, as depicted in Fig. 5. In order to increase the amount of data available, and therefore increase the precision of the synchronization one can use as many links as possible. By providing multiple independent measurements that can be averaged the noise measurement can be reduced. This approach is statistically more robust than the single linked common-view.

The error contributions that affect both LCVTT and MP-LCVTT synchronization are the same of Common View. In the next section the description of the most important errors is provided.



Fig. 4. Example of linked common-view time transfer.

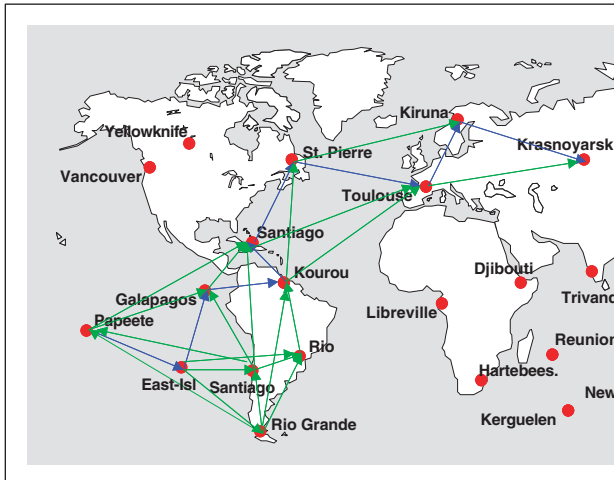

Fig. 5. Example of multiple-path linked common-view time transfer.

3.1 Error Contributions

3.1.1 Errors Resulting from Satellite Ephemeris. The time transfer error is dependent upon the ephemeris or position error of a satellite.

Common-view time transfer yields a great reduction in the effect of these errors between two stations, A and B, as compared to transfer of time from the satellite to the ground.

Common-view time transfer is accomplished as follows: stations A and B receive a common signal from a satellite and each records the local time of arrival, t_A and t_B respectively. From a knowledge of station and satellite position in a common coordinate system, the range between the satellite and each of the stations is computed, ρ_A and ρ_B . The time of transmission of the common signal according to each station is computed by subtracting from the times of arrival, the times of propagation from the satellite to each station, i.e., the time to travel the distances, ρ_A and ρ_B , are τ_A and τ_B (the range delays) and are given by $\tau_A = \rho_A / c$ and $\tau_B = \rho_B / c$ where c is the speed of light. This speed is subject to other corrections as are treated later. Finally, the time difference, τ_{AB} , of station A's clock minus station B's clock at the times the signals arrived is: $\tau_{AB} = (t_A - \tau_A) - (t_B - \tau_B)$.

If the ephemeris of the satellite is off, the computed ranges from the stations to the satellite will be off an amount dependent on the way the ephemeris is wrong and the geometrical configuration of the satellite-station systems. The advantage of common-view time transfer is that the computed bias is affected not by range errors to individual stations, but by the difference of the two range errors. Thus, much of the ephemeris error cancels out.

To see how this works in detail, suppose the ephemeris data implies range delays of τ_A^1 and τ_B^1 , but the actual position of the satellite, if known correctly, would give range delays of $\tau_A = \tau_A^1 - \Delta\tau_A$ and $\tau_B = \tau_B^1 - \Delta\tau_B$. Then the error in time transfer would be $\Delta\tau_{AB} = \Delta\tau_A - \Delta\tau_B$, where $\tau_{AB} = \tau_{AB}^1 - \Delta\tau_{AB}$ is the true time difference (clock A - clock B) and where τ_{AB}^1 is the computed time difference from the actual time of arrival measurements and ephemeris data. Thus, $\Delta\tau_{AB}$, the time transfer error due to ephemeris error, depends not on the magnitude of the range errors, but on how much they differ. The error in time transfer, $\Delta\tau_{AB}$, as mentioned above, depends on the locations of the two stations and of the satellite, as well as the orientation of the actual position error of the satellite. Since the GPS satellites are so far out, 4.2 earth radii approximately, the direction vectors pointing to the satellite tend to be close to parallel, thus cancelling most of the ephemeris error in all cases where common-view is available.

3.1.2 Errors Resulting from Ionosphere. The ionospheric time delay is given by (3) where TEC is the total number of electrons, called the Total Electron Content, along the path from the transmitter to the receiver, c is the velocity of light in meters per second, and f is the carrier frequency in Hz.

$$\Delta t = 40.3/cf^2 TEC \text{ (s)} \quad (3)$$

TEC is usually expressed as the number of electrons in a unit cross-section column of 1 square meter area along the path and ranges from 10^{16} electrons per meter squared to 10^{19} electrons per meter squared.

For low latitudes and solar exposed regions of the world, time delays exceeding 100 ns are possible specially during periods of solar maximum. It's possible to show that the total delay at night time and/or high latitude is much smaller than at day time, and that the correlation in absolute delay time covers much larger distances when one moves away from the equator and the vicinity of noon; the conclusion being that a significant amount of common-mode cancellation will occur through the ionosphere at large distances if all observations are made at either high latitudes

and/or at night time. These cancellation effects, over several thousand km, will cause errors of less than 5 ns. For short baselines less than 1000 km, this common-mode cancellation will cause errors of the order of or less than about 2 ns.

Since the ionosphere is a dispersive medium, when pseudo-range (code) measurements are available both at L1 and L2, an ionospheric delay-free pseudo-range $\rho_{iono-free}$ can be constructed with the following relationship:

$$\rho_{iono-free} = \frac{f_{L1}^2}{f_{L1}^2 - f_{L2}^2} \rho_{L1} - \frac{f_{L2}^2}{f_{L1}^2 - f_{L2}^2} \rho_{L2} = \frac{\rho_{L2} - \gamma \rho_{L1}}{1 - \gamma} \text{ (m)} \quad (4)$$

where $\gamma = (f_{L1}/f_{L2})$.

It's also possible computed ionospheric delay (seconds) with the following equation:

$$\Delta t_{iono} = \frac{1}{c} \frac{f_{L2}}{f_{L1} - f_{L2}} (\rho_{L1} - \rho_{L2}) \text{ (s)} \quad (5)$$

If double frequency measurements aren't available, the ionospheric delay can be estimate using Klubachar model (possibly corrected by the difference in height of the satellite with respect to an Earth observer). This model use the eight ionospheric coefficient that each satellite transmit with the Navigation Message. This model can be used to determine the delay in the vertical direction relative to a certain position from four amplitude components and four periodic components; this method is said to be capable of correcting about 50% of ionospheric delay.

3.1.3 Errors Resulting From Troposphere. In transferring time between ground stations via common-view satellite, one records the time arrival of the signal and computes the time of transmission by subtracting the propagation time. The propagation time is found by dividing the range to the satel lite by the velocity of light. However, moisture and oxygen in the troposphere have an effect on the velocity of propagation of the signal, thus affecting the computed time transmission and therefore, the time transfer. This effect is dependent on the geometry, the latitude, the pressure, and the temperature, and may vary in magnitude from 3 ns to 300 ns. However, by employing reasonable models and using high elevation angles, the uncertainties in the differential delay between two sites should be well below 10 ns. Later on, if needed, the magnitude of the troposphere delay can be calculated with uncertainties which will approach a nanosecond.

For the implementation of the Synchronization algorithm same tropospheric model are used. If for a station measurements of pressure, temperature and relative humidity are available it's possible use a mathematical model to estimate and remove the tropospheric delay. In the following Hopfield Model, with Seeber Mapping function or trough Series Expansion of Integrand, and Saastamoinen model are used.

3.1.4 Errors Consideration in Receiver Design. A common concern for all modes of extracting time from GPS/GALILEO is the calibration. The precise calibration bias of a GPS/GALILEO system (including receiver, antenna and cabling) typically is one of largest errors in providing time offset between two stations.

Absolute calibration can be achieved by using a GPS/GALILEO signal simulator to calibrate the group delay trough the GPS/GALILEO antenna, receiver and

cables. Calibration is more commonly achieved by using a GPS/GALILEO receiver whose calibration has been previously determined. Using great care, the calibration bias can be reduced to less than 5 ns.

Even in the best-designed system, GPS/GALILEO receivers can vary by several nanoseconds in their calibration over time (months to years). It's important to frequently check the calibration of the GPS/GALILEO System.

Multipath is a well know error source for all forms of GPS/GALILEO observations. However, timekeeping has an added multipath concern due to reflections in the cabling. Care should be taken in impedance matching between the elements of the user's GPS/GALILEO System. Failure to do so can cause large temperature and time-dependent variations in the measurements (up to 10 ns).

It's not possible decrease the impact of the receiver delay error averaging many independent time offset value because this error component affect alike all measurements. For this reason it's important know precise receiver time delay. If the calibration delay is known, after removing, the pseudo-range observables can be considered free from this error contribution. In the following section the LCVTT and Multiple Path LCVTT algorithm implementation is discussed.

3.2 Synchronization Algorithm Implementation

The planning of the multiple path LCVTT requires an evaluation process of average number of satellite in common view for the path linking each station. Through SVs constellation simulator it's possible to obtain the common view visibility data that can be used to evaluate each possible link path. This, in turn, allows to optimize the path selection (Fig. 6) used to synchronize all network stations.

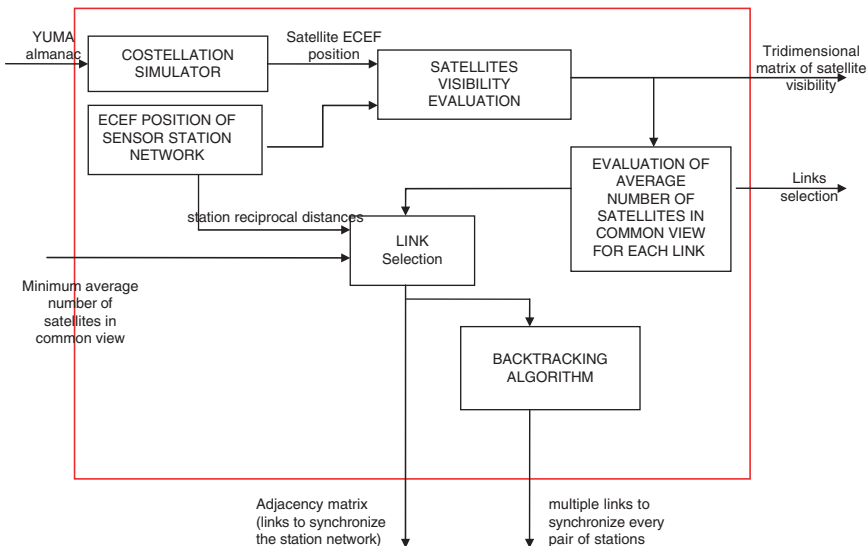

Fig. 6. Path selection block diagram.

For GPS, the metric used to select a contributing link is based on common observation times for each station connected to adjacent stations via LCVTT. It is possible to precompute the number of common observations from the reference site to each of the adjacent sites, and the higher this value, the better the link will be in providing useful data for the LCVTT. A second metric is based on the average number of SVs in common view over each of the paths; a large number of SVs implies again that more time transfer will be available and that the measurement noise will be smaller as a consequence of averaging a large number of raw time transfers, each of which will result from one of the SVs in common-view.

Common-view visibility data, provided by the SVs constellation simulator, is used to fill the metrics used for each path link evaluation. This in turn allows to optimize the path selection, leading to a ground network topology for the LCVTT. In operations, the raw data from the Sensor Stations is sent to the LCVTT computations process, for elaboration and estimation of time offset between individual pairs of station clocks (synchronization value).

For each link identified at the output of Link Selection Block, the CV Synchronization Algorithm is applied as depicted in Fig. 4. By receiving in input the pseudorange measurements of the identified satellites, k values of CV synchronization can be computed for that link (where k is the number of satellites in CV of station i and j), by applying the CV Synchronization Block (detailed in Fig. 5). The final synchronization value at instant t for station i and j can be obtained by averaging all synchronization values obtained for this pair of stations from the pseudorange related to all the k satellites in CV.

By means of the “Adjacency Matrix” (output of the Link Selection Block of Path Selection algorithm), this can be iteratively applied in the MLCVTT to all the possible links that cannot be directly synchronized via single CV, by applying a backtracking algorithm to identify the possible multiple paths. The synchronization values for each link is obtained by applying the LCVTT Block (Figs. 7 and 8) for those paths identified at the output of the Backtracking Block (average value for each pair of station is again obtained for each instant by averaging over all the satellites in CV for each individual link).

The Stand Alone Synchronization Block returns the pseudorange of each Sensor Station to be synchronized, after removal of ionosphere, troposphere, equipment delays and true slant range, in order to obtain the Space Vehicle (SV) and Sensor Station (rx) clock contribution, considering that measured pseudorange (as obtained at output of Sensor Station receiver) can be defined as:

$$\rho_{measured} = \rho_{true-range} + c\Delta t_{iono} + c\Delta t_{tropo} + c\Delta t_{sv} + c\Delta t_{rx} + c\Delta t_{equip} + \varepsilon \quad (6)$$

Please refer to Fig. 9 for the Stand-Alone Synchronization algorithm Block Diagram.

Validation of the developed algorithms in terms of the achievable synchronization accuracy is performed by running the developed algorithm with input pseudorange measurements as collected at IGS worldwide Ground Stations and comparing the Ground Station Synchronization results obtained as output of LCVTT and MPLCVTT with IGS clock Products as provided by International Geodetic Service (IGS). In the following section the experimentation results are presented.

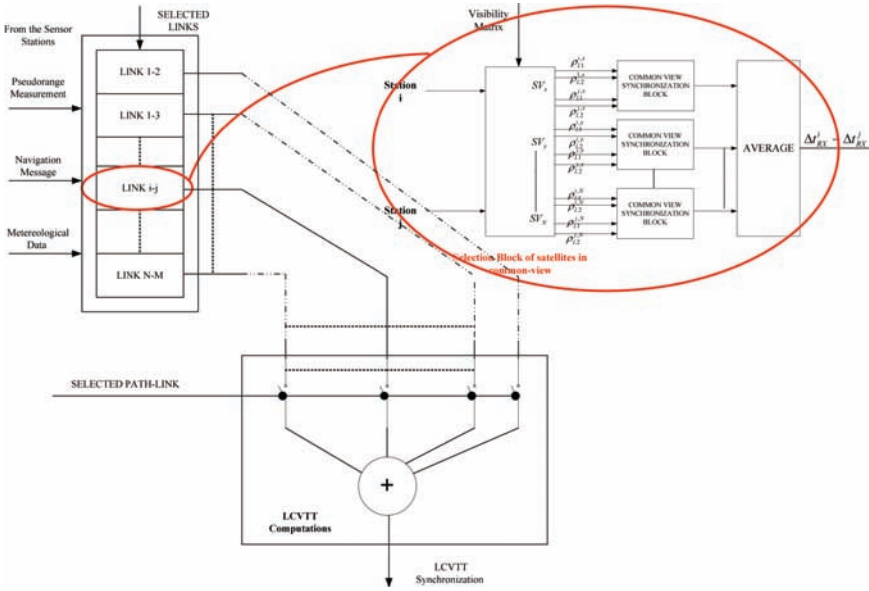

Fig. 7. LCVTT block diagram.

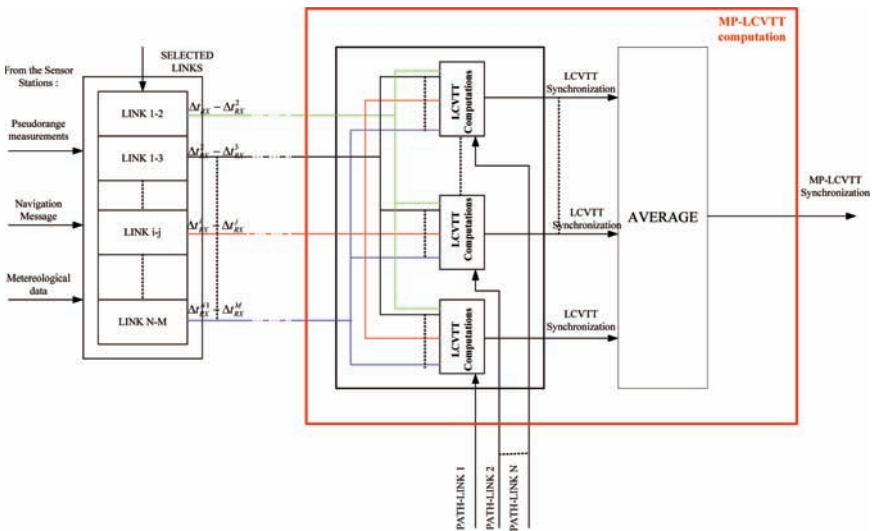

Fig. 8. Multiple path LCVTT block diagram.

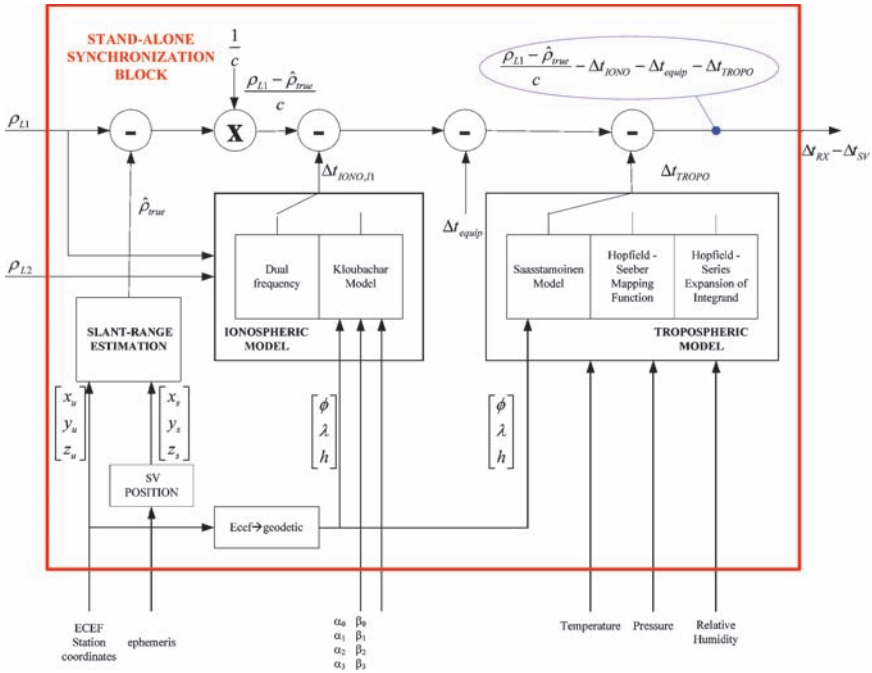

Fig. 9. Stand-alone synchronization block diagram.

4 Experimentation Results

Preliminary experimentation results are obtained running the prototype algorithm (either LCVTT and MLCVTT) by processing in input code measurements acquired at the IGS Sensor Stations as indicated in Fig. 10 (and retrieved at <http://igscb.jpl.nasa.gov>) and by comparing the obtained outputs with IGS clock products (available at same web site). Only data from Sensor Station that are found complete of all needed informations to efficiently remove pseudorange error contribution (meteo data, equipment calibration data etc.) are used to obtain the results shown in Figs. 11–13. The figures shows the comparison of the synchronization between pair of stations, obtained with single-path and multiple-path linking, with the synchronization computed by IGS for the same pair of station (considering IGS as the “true” reference).

As expected, the synchronization error decreases with the distance of the two stations because pseudorange measurements are affected by error that are not common and cancel out only at first order; the advantage is that using LCVTT it’s possible recover the time offset between two stations not in common visibility. Moreover, by averaging multiple independent estimates of the time transfer from the multiple path, the LCV timing stability (at 1 day averaging) can be increased with Multiple Linked Common View.



Fig. 10. IGS sensor station network.

To be able to obtain the same performance of single Common View (stability around 5 ns rms at 1 day) for all the Sensor Station Synchronization (including Stations not in view) using Multiple LCVTT we need many stations to increase the number of independent measure of the clock offset. If it's not possible to use an enough number of stations, the synchronization suffers the dominance on the linking process of single noisy link.

5 Conclusions

Both Linked Common View and Multiple Path Linked Common View have been implemented in a combined algorithm. The algorithm is run by processing the measurements as collected by the International GPS Service (IGS) and output synchronization products are compared with IGS products for algorithm validation. In particular the improvement obtained with Multiple Path LCVTT when compared with Linked Common View is shown based on experimentation results. MP-LCVTT can be advantageously implemented to guarantee the synchronization of those stations that are located at intercontinental baseline and for which a continuous

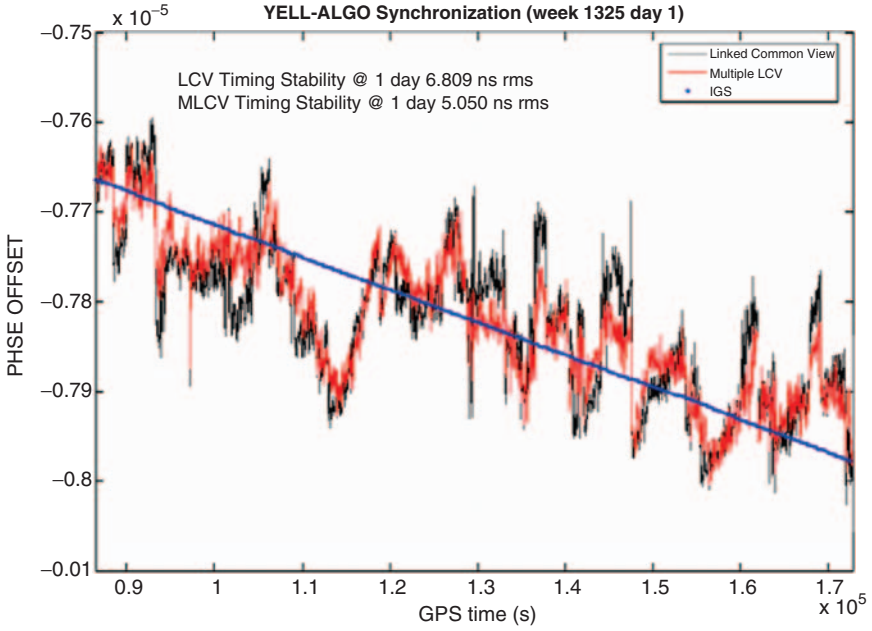

Fig. 11. YELL-ALGO synchronization.

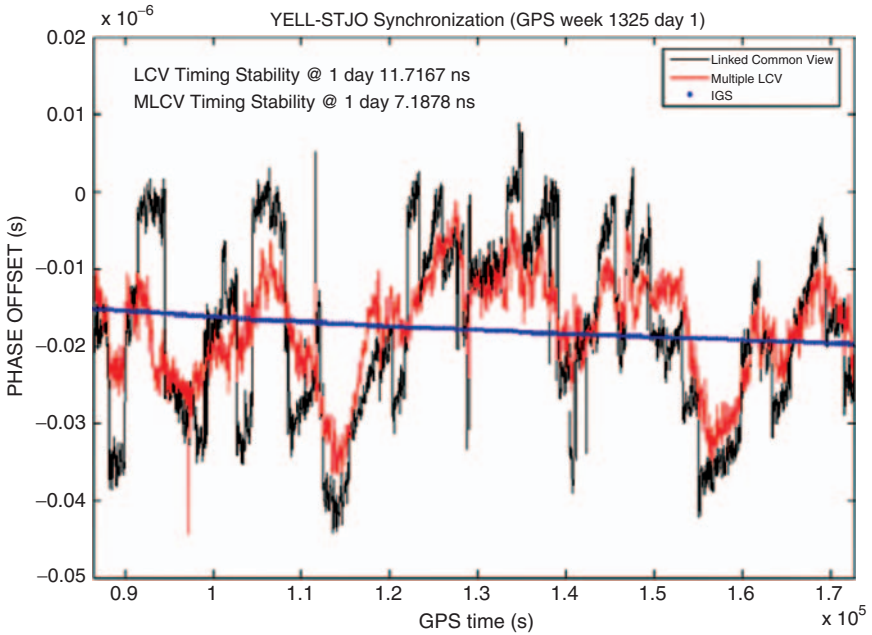

Fig. 12. YELL-STJO synchronization.

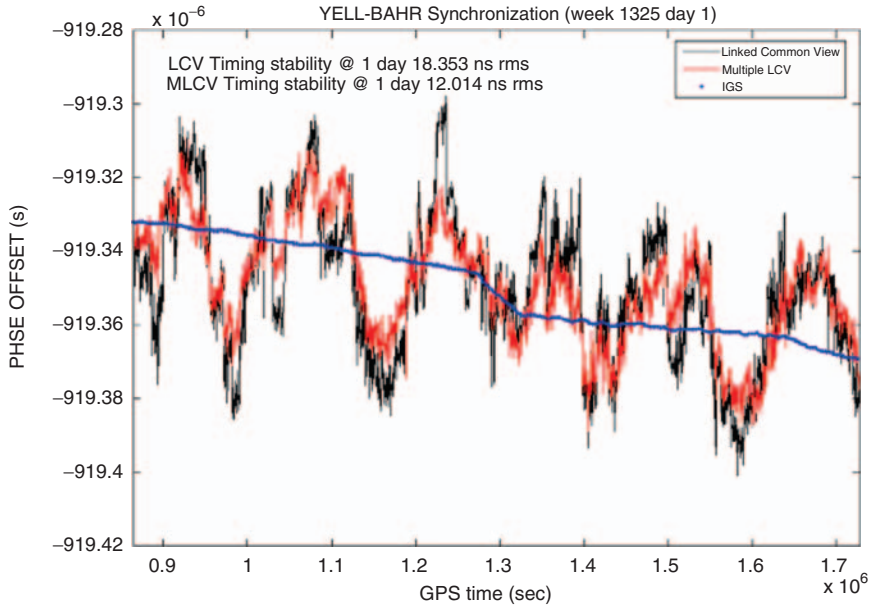

Fig. 13. YELL-BAHR synchronization.

synchronization would not be differently possible. As expected, the performance of synchronization achievable by combining adjacent links is worst than single CV (CV time stability around 5 ns rms at 1 day) as the CV errors sum as the square root. However this can be compensated, in MP-LCVTT, by the reduction in the measurement noise resulting from the averaging of multiple, independent time transfers from multiple links to a given site. The experimentation campaign allowed to confirm this expectation, considering that:

- All the considered sensor station (world-wide distributed) are synchronized with an error between 2 and 12 ns rms at 1 day
- This result is considered a worst case, as the experimentation results are limited and constrained by the sensor station measurement quality and choice that has been used for the experimentation campaign.

The sensor station network is in fact non-optimal in terms of number of stations and quality of measurements acquired by them. This is due to the fact that the selection of the sensor station network has been driven by the availability, for each of them, of all the information necessary to efficiently reduce the error contribution (e.g. availability of dual-frequency receiver to remove the ionospheric delay and of meteo data to remove the tropospheric delay) and, at the same time, availability of the IGS products (for those Sensor Stations) to be used as reference for the algorithm validation. These constraints led to the selection of number of stations that is

limited and characterized by an highly variable and not optimized measurement quality. It has to be noted that the noise affecting the pseudorange measurements is directly impacted by the quality of the oscillator feeding the receiver (that in the selected network is not always represented by an high stable atomic clock, sometimes being an internal quartz) and by the calibration of the station equipment delays (that are often not available for the selected sensor stations and thus was not possible to remove it).

These limitations would not apply when the same algorithm would be used by processing Galileo measurements as acquired at Galileo Sensor Stations (GSS); in this case calibration data will be regularly available and all the Sensor Stations will be equipped with high stable atomic clocks, whose performance will be aided by use of temperature-stabilization systems.

Therefore it is expected that the performance achievable by the developed algorithm, when applied to Galileo Sensor Station Synchronization, is sensibly better and adequate to the initialization of System in its IOV Configuration.

References

- [1] O. Galimberti, M. Gotta, F. Gottifredi, S. Greco, M. Leonardi, F. Lo Zito, F. Martinino, S. Piazza, M. Sanna, "Galileo: The European Satellite Navigation System", Proceedings of ATTI dell'Istituto Italiano di Navigazione, March 2005, p. 50–96
- [2] K. Ghassemi, S.C. Fisher, "Performance Projections of GPS IIF", Proceedings of the 10th International Technical Meeting of the Satellite Division of the Institute of Navigation, ION GPS 1997 Meeting (Kansas City, Mo. – September 16–19, 1997), pp. 407–415
- [3] P. Tavella, M. Gotta, "Uncertainty and prediction of clock errors in space and ground applications", in Proc. 14th European Time and Frequency Forum, Turin, March 2000.
- [4] W. G. Reid, 1997, "Continuous Observation of Navstar Clock Offset from the DoD Master Clock Using Linked Common View-Time Transfer," in Proceedings of the 28th Annual Precise Time and Time Interval (PTTI) Systems and Applications Meeting, 3–5 December 1996, Dana Point, California, USA (U.S. Naval Observatory, Washington, D.C.), pp. 397–408.
- [5] W. G. Reid, 2000, "Multiple-Path Linked Common-View Time Transfer," in Proceedings of the 31st Annual Precise Time and Time Interval (PTTI) Systems and Applications Meeting, 7–9 December 1999, Dana Point, California, USA (U.S. Naval Observatory, Washington, D.C.), pp. 43–53.
- [6] T. E. Parker, D. Mtsakis, "Time and Frequency Dissemination – Advances in GPS Transfer Techniques", GPS world, November 2004.